

Harmonic Mixers for Spectrum Analyzers



**Doug Millar
K6JEY**

Analyzer Circuits

- Normally the harmonic mixer bypasses the front end of the analyzer and goes to the IF. HP-300Mhz, Tek 2GHz
- On the modern analyzers there is a setting for conversion loss vs. frequency to give “calibrated” amplitude values.
- Mixer bias can usually be adjusted for best sensitivity. Usually manual on older units. “Mixer bias” control.
- The LO and IF have to be fed to the mixer. Some do it internally and others externally. Little difference. Use very good cables on the LO.
- The IF output low pass filter is usually very broad, so mixers can be swapped.

First- the three types of mixers.

- **Point Contact diode-** whisker and wafer type
 - Tektronix mixers
- **Beam Lead-** on a substrate with connections
 - HP modern designs
- **Cartridge-** like 1N23 or 1N78 types.
 - Older designs. Good up to 40GHz
 - Have an option to test before you buy.
 - Most are 5db noise figure and up.

Extending the Frequency

- Most mixers are primarily limited by the waveguide type
- Secondarily by the diode type
- WR 22 or 28 is a good compromise.
- It's lower frequency is 26ghz or so.
- WG can be used well at twice its maximum frequency $50 \times 2 = 100\text{GHz}$.
- You can mate some different WG types with minimum loss or mode problems.

Tektronix Mixers

- Two series of mixers:
- **The WM490 and WM780.** The 490 no calibration chart. The 780 has a built in chart. The suffix tells you the band they are designed for.
- **The diode is a point contact type and will only take 32mw. It is also sensitive to impact.**
- Both need to be properly biased.



WM490 Design

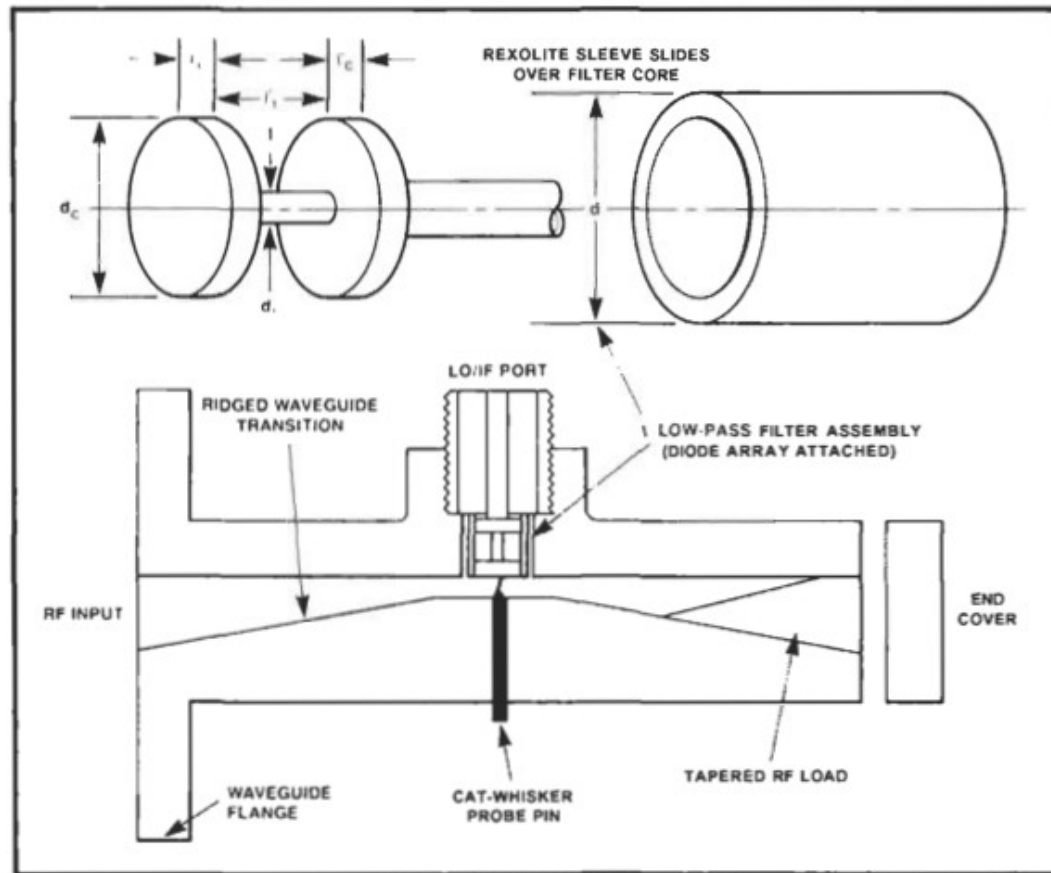
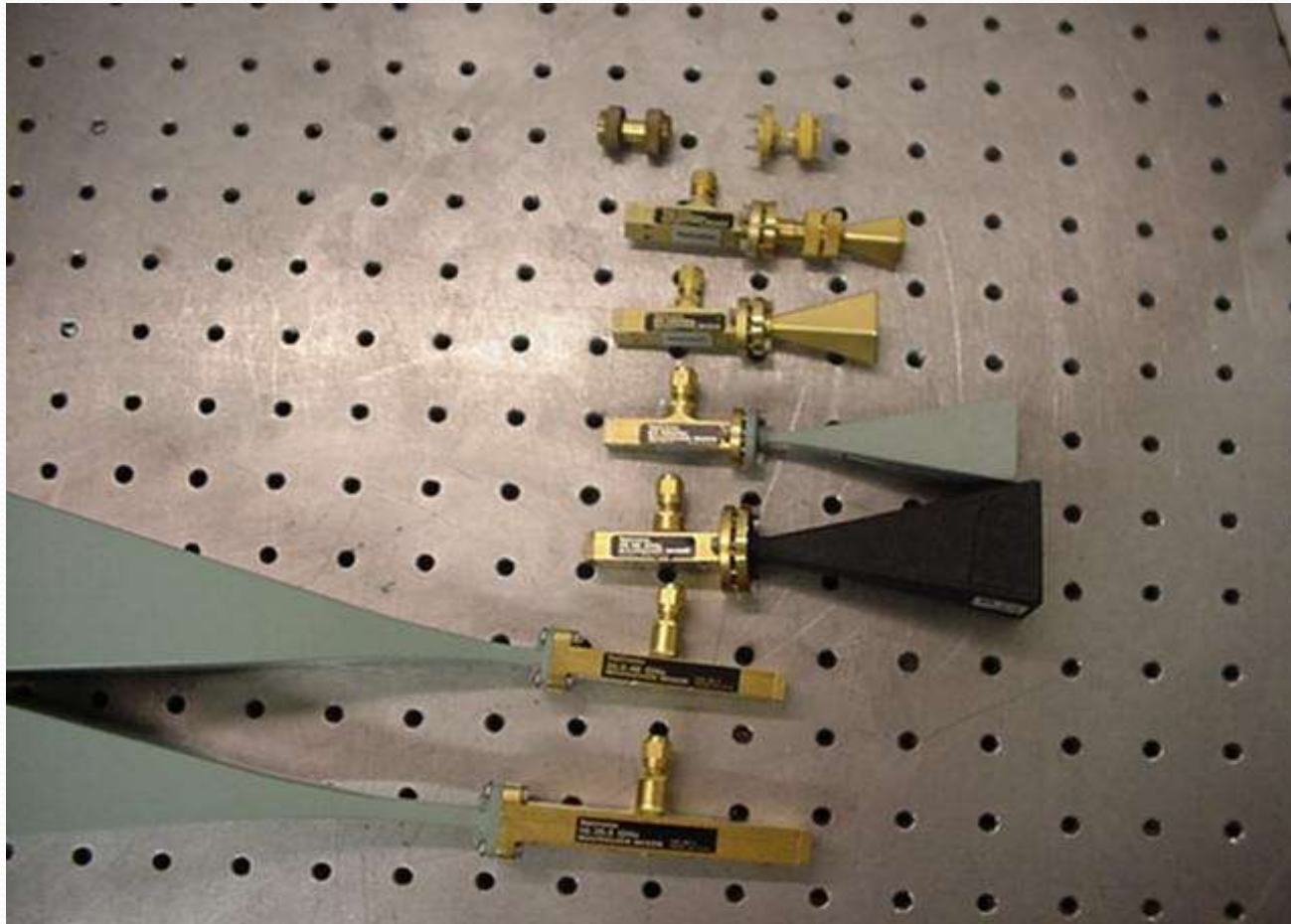

Figure 10. Millimetric mixer construction.

*A tip of the hat to
Alan Devlin
VK3XPD*

The Complete set of WM490 mixers and horns. \$5-20,000



WM780

The Cal Chart is on the other side. WR10



**Tektronix
WM782V mixer
chart.**

**Remember to
cover the WG
opening.**

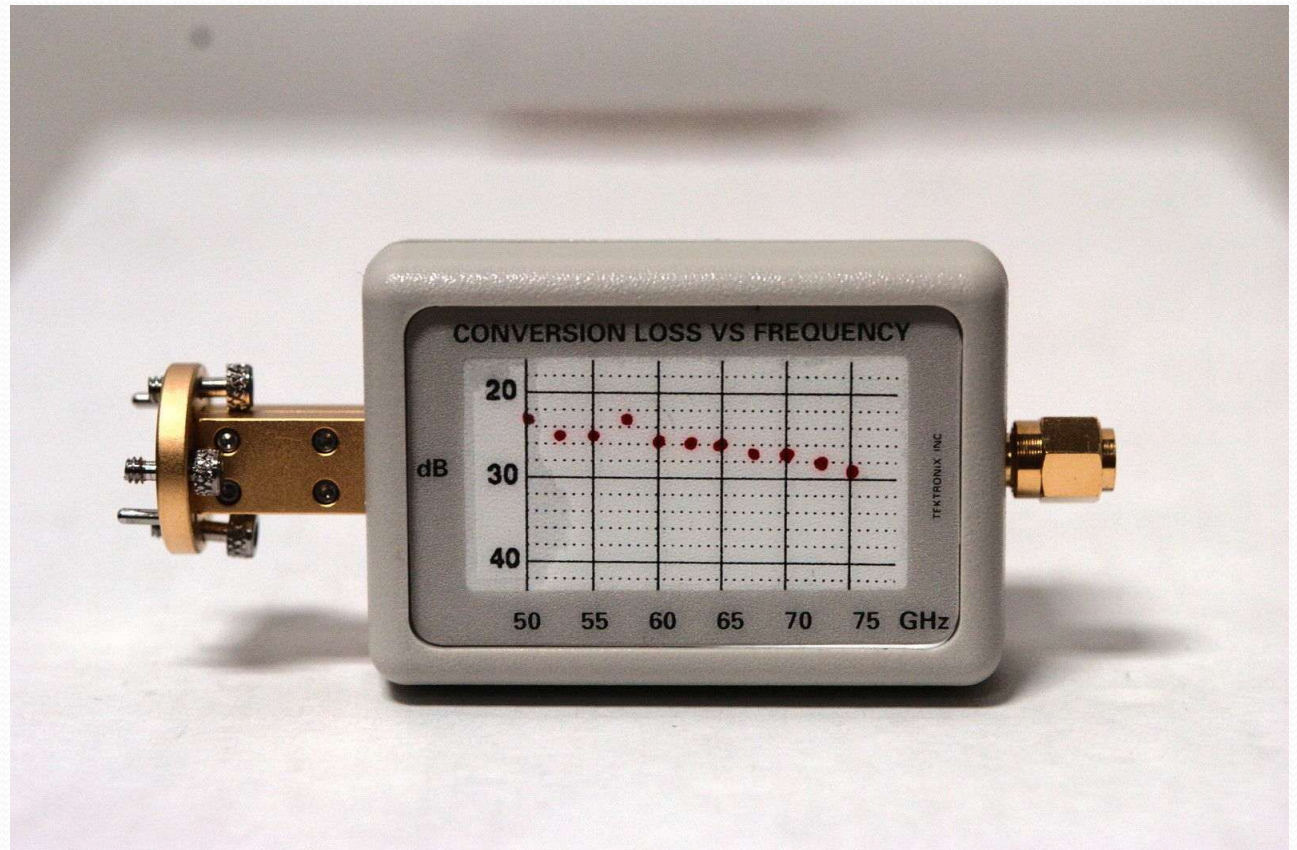

More Details on Tek Mixers

- All of the Tek mixers are two port- an input and IF. To work with some analyzers they have to have a diplexer to combine the IF input and the LO output to the mixer.
- It is possible that the only difference in mixers is their waveguide.
- TEK uses the same diode in all of them. However, since the diode whisker is hand placed, each mixer could be quite different. Conversion loss is about 25-35db.

HP Mixers

- Three port types that don't need a diplexer.
- They use diodes on a substrate and are quite physically robust
- They do use the same diode in all the mixers
- Cable loss in all the mixers is important
- The IF of the HP mixers is about 310MHz.
- The fundamental RF range is 2-6GHz
- They will also take 200mw.

HP 11970 Series Mixer

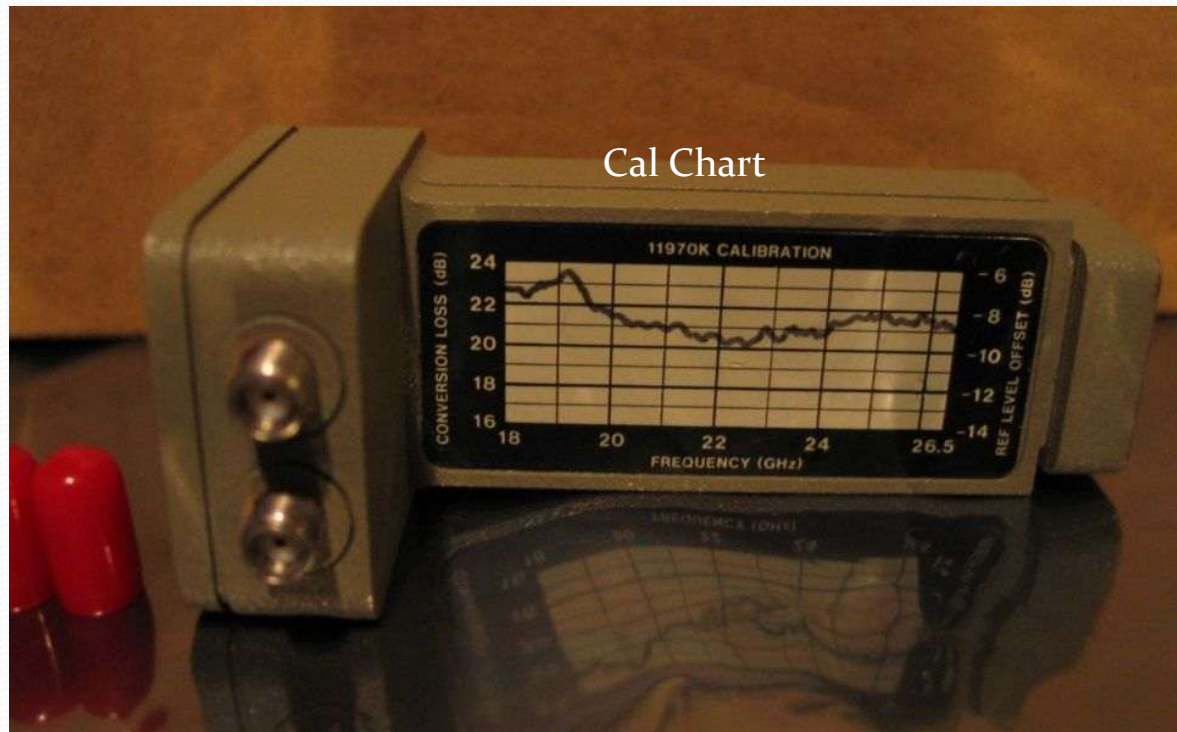

Miscellaneous Mixers



Inside the Phillips Mixer

Originally designed for 40GHz with a tapered feed and a great diode.

It works well on Tek and HP analyzers

It works well up through 120GHz!

Not bad for \$50 or less.



Outside

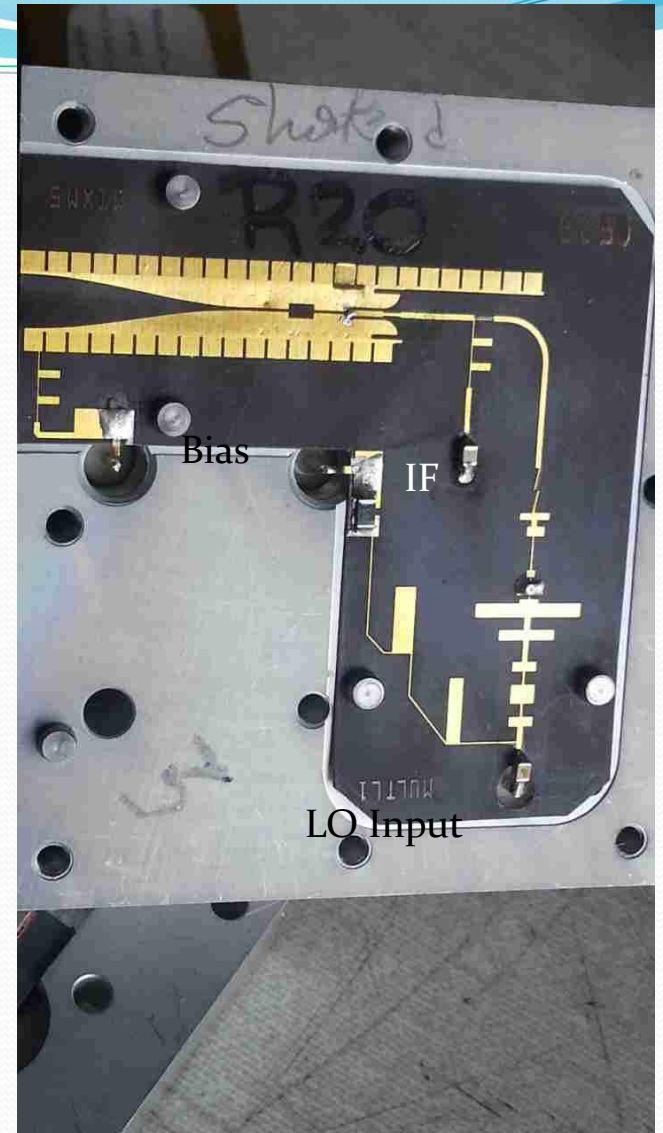

Finline or Vivaldi
Feed

Use The LO input for
connection to the Spectrum
Analyzer

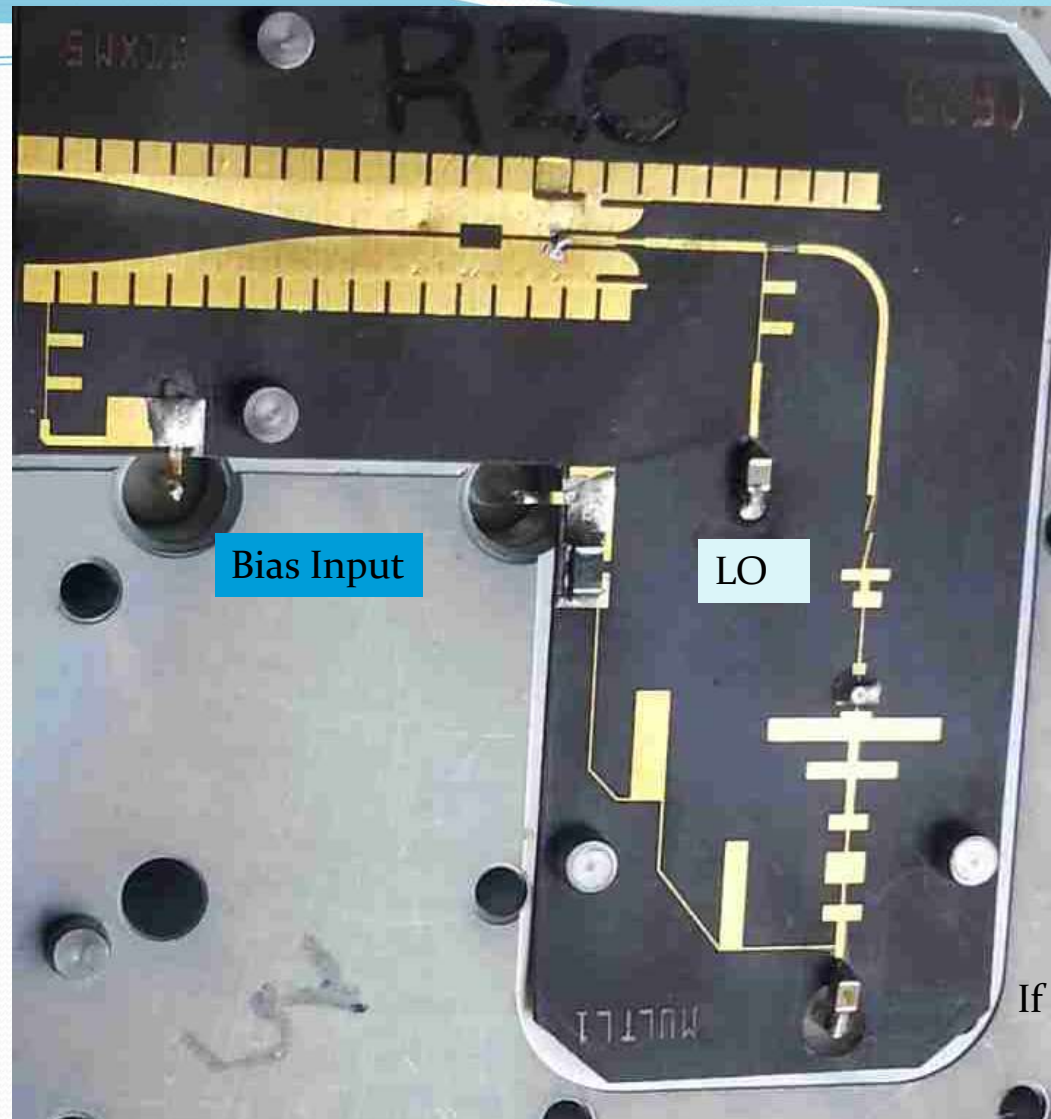

If Output

SD Cartridge type Mixer





Mixer Comparison

- I ran tests on all the mixers I had at 79 and 120GHz .
- I compared the peak amplitude of the signal with each one.

Test Data at 79GHz

Rank	Mixer	DBm
1	HP 11970Q (33-50GHz)	-24
2	Spacek WR 10	-28
3	Phillips	-33
4	WM490U (40-60GHz)	-36
5	WM780W (75-115GHz)	-44
6	Cube (35GHz)	-45
7	FXR (WR12)	-57

Test Data at 119GHz

Rank	Mixer	DBm
1	Phillips (with WR28 horn +10db)	-55
2	WM490U (40-60GHz)	-57
3	Spacek WR 10	-58
4	Cube (35GHz)	-58
5	HP 11970Q (33-50GHz)	-63
6	WM780W (75-115GHz)	-66
7	FXR (WR12)	-75

Combined Test Data

- Based on using an HP 8563A analyzer and Tek duplexer as needed.

Mixer	DBm at 79GHz	Rank	DBm at 119GHz	Rank
HP 11970Q (33-50GHz)	-24	1	-63	5
Spacek WR 10	-28	2	-58	3
Phillips	-33	3	-55 WR28 horn +10db	1
WM490U (40-60GHz)	-36	4	-57	2
WM780W (75-115GHz)	-44	5	-66	6
Cube (35GHz)	-45	6	-58	4
FXR (WR12)	-57	7	-75	7

Conclusions

- The Phillips box comes out on top for price/value
- The HP works nicely out of its range. Second best value.
- The WM780 did not do well, but it is calibrated.
- The FXR is an older type. Most don't do well.
- All of the mixers give an adequate S/N for adjusting rigs.
- The SDMC mixer by Kerry Banke did very well on 79GHz.

Miscellaneous Mixers



Observations about buying mixers

- Beware of cheap mixers.
- Do not assume that an expensive one is better.
- You will pay a premium for higher frequencies. It is better to make a lower frequency item to work at higher frequencies.
- The mixers with a cartridge diode don't do well above 40GHz or so.
- the S/N ratio came out the same on the HP8563A and the TEK 494AP.
- An IF amplifier might help the IF noise figure by maybe 5db.

Mixer Tricks To Improve Performance

- Lower multiplication number of the LO.
- You can make an LO signal source so that there is little or no multiplication in the mixer. Easy since we are interested in fixed bands.
- In your transverter, use your mixer as a multiplier for greater output. It takes 2 LO's but it is worth it.
- For the experts you can flake some of the mixers
- You can change the diode to a better type.



Operational Advice

- LO drive is important. Minimize losses
- If using a tripler to generate harmonics, don't forget to include its total energy in calculating how much power is going to the mixer.
- Keep your Tek mixers in a padded box. Don't even drop them on the desk.
- Keep track of your measurements
- Don't confuse a detector with a mixer.



Questions?

- Contact info
- Doug Millar K6JEY
- drzarkof56@yahoo.com